

# NORITSU

Pharmacy Automation

# NX4000

## STRIP POUCH PACKAGER



The strip pouch packaging system has not only improved our pharmacy efficiency and safety, but the ability to tie into our eMar [electronic medication administration record] system creates less steps in the administration process

**Ross Brickley**  
Vice President of  
Pharmacy Services  
~ *Neil Medical*

**Fast, accurate, and  
built to last.**

Maximize your workflow with access to over 2400 unique medications using our U2 zone technology and NexusRx Workflow Suite



- Unrivaled **PRECISION**
- Field-Proven **RELIABILITY**
- Increased **PILL VELOCITY**
- A partner you can **TRUST**

# Is your workflow as efficient as it could be?

The NX4000 is purpose-built to meet the needs of high-demand pharmacies. This reliable and flexible solution accurately fills orders from an array of easily managed cassettes and via our innovative in-line tray loading system for uninterrupted production.

## Built To Last



Nothing is more costly or frustrating than unnecessary downtime. Our systems are built to exacting standards with the highest quality materials to maximize reliability. Schedule a discovery meeting today and see the difference for yourself

## Intelligent Software



Inefficient workflow can be a major cause of bottlenecks in your production. Our unique Virtual Release technology and intelligent order processing help alleviate interruptions by planning the best use of resources prior to starting a production run. Uninterrupted production means less labor and faster throughput

## Unmatched Service



We know that choosing a new technology partner can be hard. With over 40 years of field support experience, Noritsu strives to be more than just a vendor. We will be there with ongoing support, helping to fine-tune and improve your systems based on your needs

## Noritsu Perfect Pouch

Offer your clients increased safety and ease-of-use with fully customizable pouch printing. Easily create unique pouch layouts for all of the facilities you service

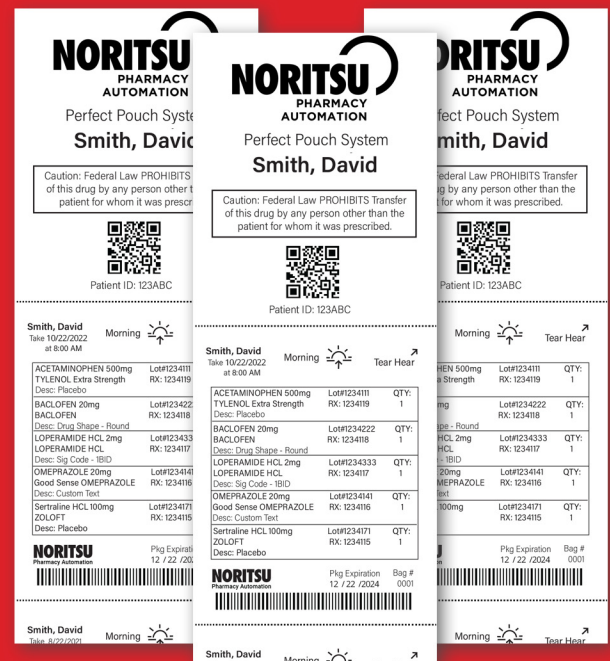

## Specifications

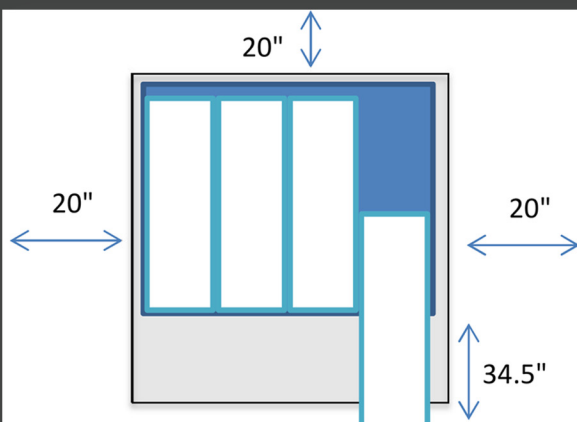

NX4000 machine dimensions  
w 47.25" x d 41.3" x h 78"

### NX4000 System Specifications

Control System	Microcomputer control
Medicine Storage	Vertical sliding cabinet
Number of Cassettes	400 IF Rotary Cassettes
Dispensing Speed	Burst Rate up to 55 pouches / min
Dimensions	W. 47.24" - D. 41.33" - H. 78.15"
Weight	1958 lbs without cassettes
Operating Environment	Temp. - 59-95 ° F / 15-35 ° C - Humidity 20-60%
Power Source	110-220V ac / 8 Amps - 60Hz / single-phase

Recommended walk and work area - **w 87.25" x d 95.8"**  
Doorway Access - **41.3" x 78"**

It is recommended to allow a working space of at least 20 inches for the back and sides of the system to allow room for maintenance, cleaning and system access.

800-521-3686 • [noritsu-rx.com](http://noritsu-rx.com) • [sales@noritsu.com](mailto:sales@noritsu.com)